

48

Mining Applications

R Hartill BSc(Hons), CEng, FIEE, Hon FIMEMME,
Eurling
Trolex Ltd

Contents

- 48.1 General 48/3
 - 48.1.1 Load growth 48/3
 - 48.1.2 Regulations 48/3
- 48.2 Power supplies 48/4
 - 48.2.1 Distribution 48/4
- 48.3 Winders 48/5
- 48.4 Underground transport 48/6
 - 48.4.1 Conveyors 48/6
 - 48.4.2 Rope haulage 48/8
 - 48.4.3 Locomotives 48/8
- 48.5 Coal-face layout 48/9
- 48.6 Power loaders 48/11
- 48.7 Heading machines 48/12
- 48.8 Flameproof and intrinsically safe equipment 48/12
 - 48.8.1 Flameproof transformers 48/13
 - 48.8.2 Flameproof switchgear 48/14
- 48.9 Gate-end boxes 48/14
 - 48.9.1 Single-point sensitive earth leakage 48/16
 - 48.9.2 Multipoint sensitive earth leakage 48/17
- 48.10 Flameproof motors 48/17
- 48.11 Cables, couplers, plugs and sockets 48/18
- 48.12 Drilling machines 48/20
- 48.13 Underground lighting 48/20
- 48.14 Monitoring and control 48/21
 - 48.14.1 Computer system 48/22
 - 48.14.2 Underground sensors 48/22

48.1 General

In order to deep-mine coal, the sinking of two vertical shafts or inclined roadways must be established to access the coal seams. Underground roadways are then established to the winning area of the coal-face. There are usually two roadways to establish a ventilation system. One shaft and roadway is used to transport the coal, the other usually to transport men and materials to the coal-face. One shaft and roadway is referred to as the *intake* and the other as the *return* airway, signifying the direction of the ventilating air flow with all precautions taken to separate the air flows to maintain adequate ventilation.

Whenever coal is mined, methane gas is liberated, and the electricity regulations require that the electrical power must be removed from that part of the mine if the methane gas content exceeds 1.25% by volume. The regulations allow an exception to this rule to permit communications and certain safety monitoring equipment to be maintained even in the heavy concentrations of methane: in this case the equipment must be intrinsically safe—that is, the equipment must be tested and it must be certified that, in the event of open sparking in either normal or faulty condition, insufficient energy would be released to ignite the most easily ignitable methane concentration.

The regulations place on the manager the responsibility to state where gas may be present in areas of the mine in sufficient quantity to be a potential hazard. In these nominated areas approved equipment is certified Flameproof (FLP) or Intrinsically Safe (IS) for Group 1 (methane) gases.

It will be appreciated that the ventilation for the dilution of liberated methane is the first safety measure in the use of electricity in mining, with the added precaution of approved apparatus should concentrations of methane occur.

Ventilation of the mine is normally achieved by reducing the pressure at the surface end of the return shaft (upcast) by means of an axial- or radial-flow fan, one fan working and one fan on stand-by. A typical installation would operate at 10–15 in water gauge (2.5 kPa) and 125–250 m³/s air flow. Since the fan is running continuously, efficiency is of prime importance: consequently, detailed attention is paid to this factor. The prime mover used is a cage or slip-ring induction motor, or a synchronous machine with speed change effected by gear or V-belt drive. More recently, variable-speed machines have been used such as a.c. commutator motor, Kramer, cascade arrangements and the pole-amplitude modulated (PAM) motor.

Where underground workings are extensive it may be necessary to provide booster fans in the underground system, usually powered by cage motors up to 400 kW.

In order to ventilate single headways, i.e. roadways being driven, auxiliary ventilation fans are used providing air at the end of the tunnel by ducting. These are smaller machines of 10–35 kW and, where they are exhausting, a situation could exist where gas flows over the fan blades; in this condition it is important to ensure that sparking cannot occur at that point. For this purpose vibration monitoring is extensively used. Two frequency ranges are monitored (500 Hz and 5000 Hz) to detect bearing failure and mechanical imbalance. The equipment will first give a warning and later 'trip the power' if the force on the bearing or imbalance exceeds the preset value.

For some years the analogue computer has been used for ventilation calculations for a mine, but is now being superseded by digital computer techniques.

48.1.1 Load growth

All activities at the mine make extensive use of electricity. Steam winders are being eliminated and compressed air as a power medium is almost non-existent. Coal is now almost exclusively won by electrically powered machines, and roadways are driven by large roadheading or tunnelling machines with extensive use of electronics to provide protection, control and monitoring. The trend in electricity consumption over the recent past is shown in *Figure 48.1*.

48.1.2 Regulations

Rules were introduced for electricity in mines in 1905. These became statutory when they were replaced by Part 3 of the General Regulations dated 10 July 1913 (SR&O 1913 No. 748) made under the 1911 Coal Mines Act and relating to Electricity in Mines. In 1954 the duties of mine electrical staff were set out in the Coal Mines (Mechanics and Electricians) General Regulations 1954.

With the advent of the 1954 Mine and Quarries Act, the above were revoked, replaced and their scope increased during the years 1956 to 1965 by new legislation as follows:

The Coal and Other Mines (Electricity) Regulations 1956
 The Miscellaneous Mines (Electricity) Regulations 1956
 The Coal and Other Mines (Safety Lamps and Lighting) Regulations 1956
 The Coal and Other Mines (Mechanics & Electricians) Regulations 1956

Other regulations, although not dealing directly with electricity, had some effect on its use. For example, Regulations relating to Qualifications (MQB Rules), Shot firing, Ventilation, Locomotives, General Duties and Conduct. All of which are printed in *The Law Relating to Safety and Health in Mines and Quarries, Parts 1 to 4*. (Note, the booklet relating to coal mines (Part 2) was reprinted in 1979 in three sections (A, B and C), but account must be taken of any amending legislation since that date, e.g. see below.)

With the arrival of the Health and Safety at Work, etc. (HSW), Act 1974 on 1 January 1975, a programme commenced to replace all existing law made under the M&Q Act 1954 by law made under the HSW Act 1974.

To date (1990), only two principal pieces of legislation have been introduced, i.e. the Mines (Safe Exit) Regulations 1988 and the Electricity at Work Regulations 1989. Both of these are accompanied by Codes of Practice approved under Section 16 of the HSW Act and having special legal status described in Section 17 of the HSW Act.

The latter legislation revoked and replaced the Coal and Other Mines (Electricity) Regulations 1956, the

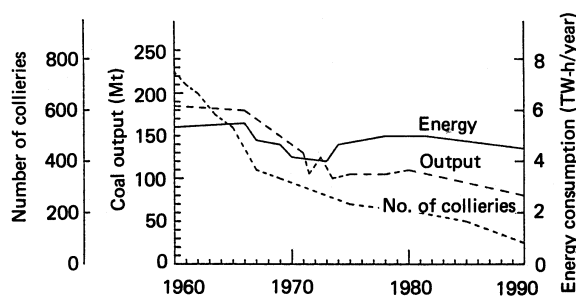

Figure 48.1 Annual coal output and electrical energy consumption (UK)

Miscellaneous Mines (Electricity) Regulations 1956, and amended several sections of other Regulations to update them and eliminate the need for Special Regulations and Exemptions which have been issued over the years to take account of modern practices and techniques.

Work is at present taking place on:

- (1) A Mines Administration Package which will revoke and replace the Mechanics and Electricians Regulations and others relating to mine management; and
- (2) A Haulage and Transport Package and a Shafts and Winding Package which will revoke and replace the Shafts, Outlets and Roads Regulations.

Note While the nationalised coal industry has changed its name from the National Coal Board to British Coal Corporation, the industry standards continue to be printed as NCB Specifications. The author has therefore used BCC and NCB where appropriate.

48.2 Power supplies

The supply of electricity to collieries is given priority by the Electricity Boards because of the high degree of risk to human life which could arise owing to failure of supply. Winding engines, ventilating fans and pumps are the items of prime importance if men are trapped underground, and the restoration of supply to these items, in particular, must be achieved as quickly as possible.

Before 1939 it was common for collieries to generate their own electricity supply but, with the advent of mechanisation of underground operation, there was a dramatic increase in demand. It was at this period that mine generation was eliminated and supplies taken from the Electricity Boards. Small generators are, however, being introduced, powered by gas engines or turbines burning methane gas extracted from the mine.

The supply usually takes the form of an Electricity Board primary substation located adjacent to the colliery premises into which a duplicate supply is taken at 33, 66 or 132 kV. Alternatively, the colliery may be fed with at least duplicate supplies from the Electricity Board's 11 kV network.

To comply with the requirements of *NCB Mining Department Instruction PI/1957/31*, Electricity Boards are required to provide a minimum of two supplies to a colliery, each supply being taken from a separate point in the Electricity Board's network and routed so as to prevent a complete failure due to a common hazard. Each supply must be capable of handling the full output of the colliery (in the case of a large modern mine, 15–20 MV-A), the system being capable of handling the fluctuating load of electric winders, etc., which could be 3–4 MW.

48.2.1 Distribution

48.2.1.1 Surface

The supply to the colliery substation from the Electricity Board's primary substation (which is usually adjacent to the colliery) is in most cases 11 kV and consists of a minimum of two feeders. Larger collieries may have three or four feeders; a typical distribution layout for a large colliery would be as shown in *Figure 48.2*.

All incoming cables, circuit-breakers, bus-section switches and metering equipment located within the colliery substation remain the property of the Electricity Board,

whereas all outgoing circuit-breakers would be the property of the British Coal Corporation (BCC).

Large drives on the surface such as winding engines and ventilating fans are generally supplied direct from the 11 kV switchboard. To ensure continuity, such supplies are usually duplicated in the form of a ring main or duplicate feeders.

The coal preparation plant, the largest energy consumer at the surface of the mine (usually 1.5–2.0 MV-A), is also supplied direct from the 11 kV switchboard by duplicate feeders.

The greatest proportion of load at a colliery is from the induction motors (mainly cage), which leads in some cases to a low power factor on the supply. In the majority of cases this is corrected by manually switched static capacitors on the 11 kV switchboard.

It was the practice to use 3.3 kV as a standard distribution voltage for underground activities. With increase of electrical powered units in operation and increased rating of coalface machines, there may be several 500 kW units being switched direct-on-line at a distance of several miles from the pit bottom; a common distance would be 8 km. The 3.3 kV distribution voltage becomes inadequate and there has been a change to the extensive use of 6.6 kV. While 11 kV is not widely used, at present for underground distribution, flameproof 11 kV switchgear and transformers have been developed and several systems are in operation.

It is envisaged that 11 kV will become the standard underground distribution voltage for systems operating 10 km or more from the source of supply, as in undersea workings.

To provide a 6.6 kV supply for underground distribution, 11/6.6 kV surface installed transformers are used with ratings ranging from 6 to 8 MV-A. Further transformation is provided from the 6.6 kV switchboard to provide lower voltages for other surface auxiliaries such as workshops, stores, stockyards, lamp rooms, offices, pithead baths, lighting, etc.

48.2.2.2 Underground

A minimum of two h.v. supplies are provided to underground workings to increase security, being installed in each of two shafts or drifts. The shaft cables are usually 185 mm² three-core polyvinyl chloride (PVC)-double wire armoured (DWA)-PVC and are secured to the shaft wall by large wooden cable cleats spaced at approximately 25 m intervals.

At the shaft bottom, a main h.v. substation is provided from which all supplies radiate to the various districts of the mine. The supply is taken to the coal-face, where it is transformed to the coalface utilisation voltage of 1.1 kV, three-phase 50 Hz. This voltage is proving inadequate for the latest larger coal-winning machines (500 kW), in these cases 3.3 kV is being utilised.

Substations are provided at various points along the cable route to provide a h.v. supply for the main coal conveyors/haulages, etc., or a medium voltage (m.v.) 1.1 kV supply for smaller drives such as secondary conveyors, haulages, pumps, auxiliary ventilation fans, etc. It was the practice to use the utilisation voltage of 550 V for underground activities, and this still remains in some parts of the mine; this, however, proved to be inadequate for the large modern machines, e.g. coal-winning machines (shearers), roadheading machines and armoured face conveyors.

The three-phase system at the mine is earthed to its own earth plates at the surface, and is normally maintained at 2 Ω. Earthing resistors are normally included. The practice was generally to limit the earth faults to the full-load

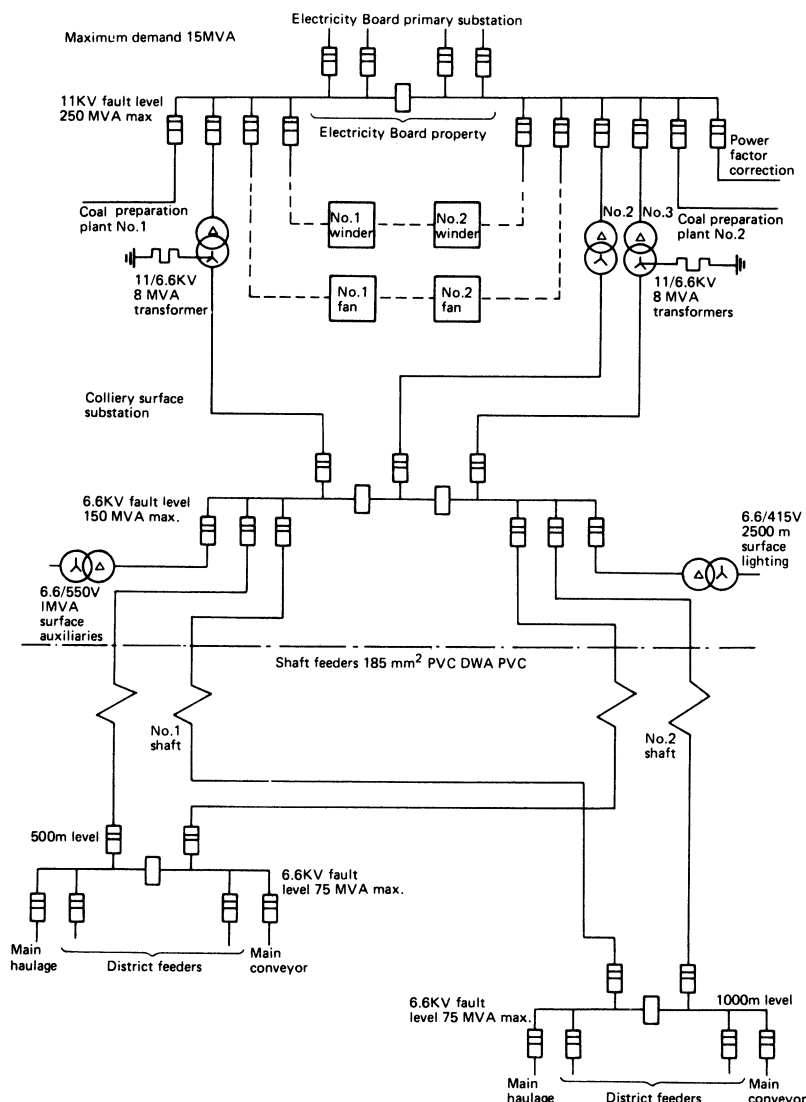

Figure 48.2 Typical colliery h.v. distribution

current of the transformer, but modern practice is to limit the 6.6 kV systems to 100 A and the older 3.3 kV systems to 150 A. Standard protection of overload, short-circuit and earth leakage is provided on the outgoing feeders.

Improved short-circuit protection is provided near the coalface, referred to as phase-sensitive short-circuit protection. This phase-sensitive protection was developed in order to permit the through current necessary to start the high-rated (500 kW) machines—which may be five or six times full-load current at a power factor of 0.2—and yet trip the supply on short-circuit of around twice full-load current which is mainly at a power factor of 0.8.

The earth-leakage protection near the face is restricted to a prospective earth fault current on the 1100 V and 550 V systems to 750 mA. Two forms are used, one a restricted core balance, the second being multiple earthing. Extensive use of electronics is made to provide the necessary detection.

48.3 Winders

Early colliery winding engines were powered by steam. Owing to the superior efficiency of electric motors and the greater ease in the provision of automatic control, nearly all winding engines in British mines are now driven by electric motors. These can vary from the very small a.c. winders in the range 100–200 kW, to the large d.c. thyristor automatically controlled winders of 4000 kW. Winding engines exist in several different forms (Figure 48.3), and, whereas the majority of the older designs were of the ground-mounted type (with unsightly headgear), new mines generally adopt the tower winder, with its cleaner lines.

Figure 48.4 shows the comparative power-time diagrams for the four different types of winding engines with the same output, net load, depth and decking time (net load, 12 t; depth of shaft, 1000 m; output, 450 t/h). There is little

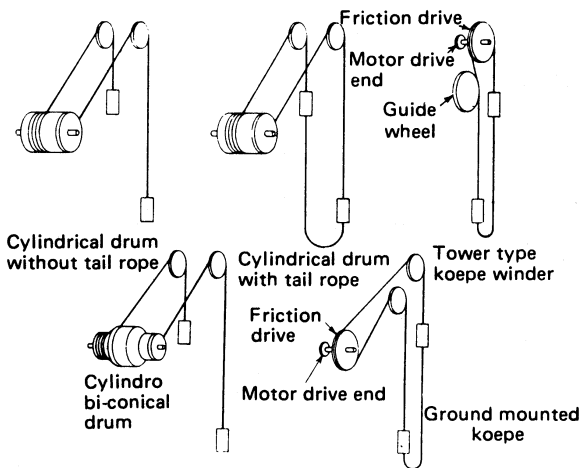

Figure 48.3 Types of winder

difference between the power requirements for a particular duty for ground and tower mounted Koepe winders, but it is obvious that a comparable Koepe winder does not need such a large motor and the energy consumption is less.

Koepe-type winders are specially suitable where extremely heavy loads are to be handled, owing to the fact that a multirope arrangement can be adopted instead of one large single rope. Two or four ropes are generally used, with special devices added to ensure that the ropes share the load equally. With Koepe winders the drive is transmitted from the winder motor by a 'friction' drive; the winding ropes may therefore have a tendency to 'creep' or 'slip'. A 'rope-creep compensating' device is provided, which automatically corrects this situation at the end of a winding cycle if it occurs, bringing the depth indicator and other safety devices into line.

Automatic winding techniques have been developed for modern winding engines, and many winders are arranged to wind coal in the automatic mode. Usually such winders

employ skips attached to the winding rope/ropes, instead of cages containing tubs or mine cars. Such skips may hold some 10/12 t and would be loaded automatically from a weigh pocket located at the side of the shaft in the shaft bottom, coal being transferred from the workings to the weigh pocket by conveyor or mine car.

As the skip arrives at the shaft bottom, it is first automatically sensed for being in the correct position and stationary. The weigh pocket door is then operated, and 10/12 t of coal is deposited in the skip in a few seconds. With the skip full and all loading/unloading doors closed, a signal is automatically given to the winding engine to start the wind. The winder is automatically started and accelerated at a predetermined rate to maximum speed. Deceleration commences at a set point in the wind, causing the winder to retard at a predetermined rate to standstill.

With the winder proved stationary and the skip in line, the surface skip door is opened, discharging the coal onto the run-of-mine conveyor at the same time as the shaft-bottom skip is being filled, the whole winding cycle being repeated automatically.

The run-of-mine conveyor transfers the newly won coal to the coal preparation plant, where it is washed, cleaned and loaded into wagons/lorries, etc., for transfer to the customer.

The most common electric winder in the UK mining industry is the a.c. winder employing the slip-ring induction motor with either liquid controller or contactor-operated metallic resistors, with a measure of speed and torque control to limit the acceleration or deceleration. Dynamic braking is used on all but the smallest winders; this is compensated to avoid saturation of the machine and ensure control. A typical layout is shown in *Figure 48.5*.

D.c. Ward-Leonard winders have been used since the turn of the century. The basic layout is shown in *Figure 48.6*. Closed-loop control was introduced to make the machine start from a signal and automatically come to rest at the surface, i.e. acceleration, deceleration, torque, current control, etc.

In the late 1950s, the mercury arc converter replaced the Ward-Leonard generator, but was replaced in the early 1970s by thyristor control. The modern machine is now fully automatic, all control and protection being solid state with thyristors in an antiparallel connection to give complete automatic winding.

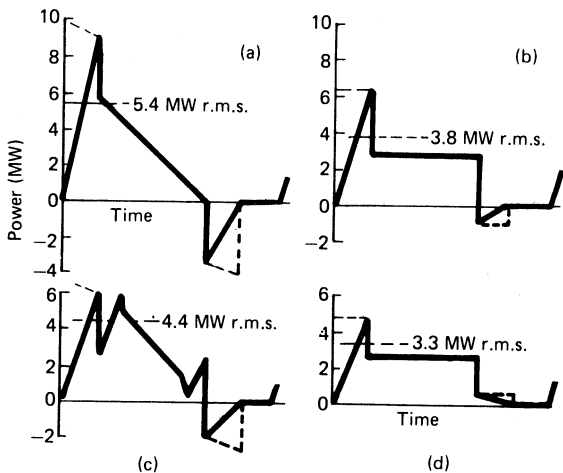

Figure 48.4 Winder power-time diagrams: (a) parallel drum without balance rope; (b) parallel drum with balance rope; (c) bicylindroconical drum

48.4 Underground transport

Coal mining has two main transport problems. One is to convey the mineral from the coal-face to the pit bottom for winding to the surface. Conveyors are the main means for transporting the mineral. The second problem is the transport of men and materials to and from coal-face to pit bottom, this is in the main either by rope haulage or by locomotives.

48.4.1 Conveyors

To meet the higher levels of coal-face performance, recent advances in the technology of conventional belt conveyor design and belting have resulted in average conveyor capacities in excess of 2000 t/h. Current underground coal transport systems utilising high-capacity belt conveyor, multi-motor drives and booster drives, together with manless transfer points, remote conveyor control techniques and sufficient automatically controlled bunkering facilities, provide the most efficient system for the tonnage rates now being produced.

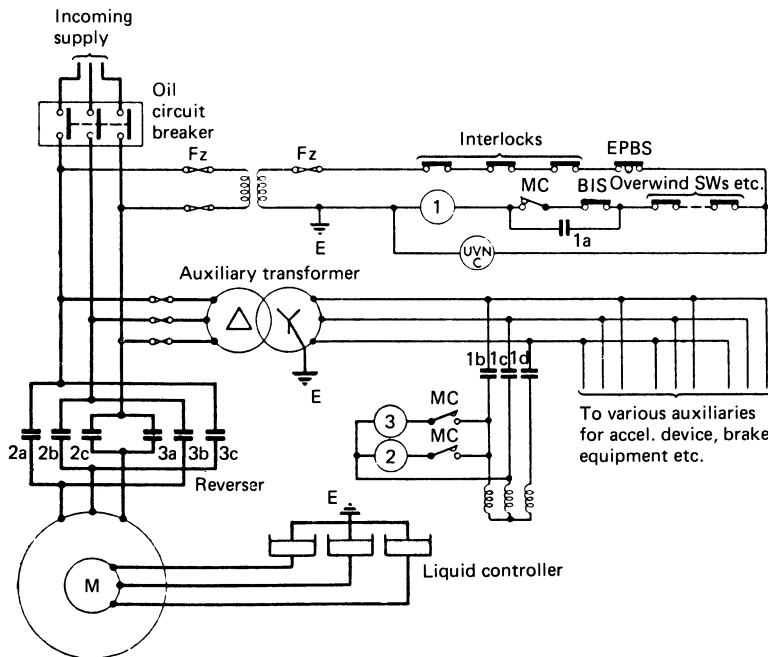

Figure 48.5 A.c. winder control

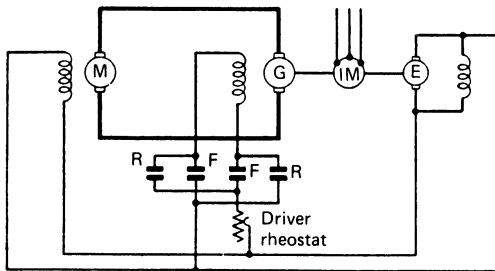

Figure 48.6 Ward-Leonard control

A Code of Practice (NCB Mining Department Instruction PI 1979/5) has been introduced, requiring full compliance to standardise on the protective devices for the safe operation of all underground roadway belt conveyor drive units. For the additional requirements appropriate to manless operation a memorandum of Guidance Minimum Requirements for Man-less Transfer Points on Conveyors was issued. The provisions of the codes are in amplification of the Health and Safety at Work, etc., Act 1974, the Mines and Quarries Act 1954, statutory regulations and mandatory BCC instructions.

The basic type of conveyor drive used underground is the solid mechanically coupled arrangement employing a single flameproof National Coal Board (NCB) specification 542 or 291 motor supplied at either 550 V or 1100 V from a standard flameproof gate-end box starter fitted with a vacuum contactor. The conveyors are started direct-on-line in sequence, and interlocked with the conveyor pre-start alarm system, signals and drive head protection sensors. Local control of starting may be used.

Main trunk roadway conveyors require higher belt speeds, coal-carrying capacities and power. To provide a soft and smooth acceleration to the belt, single- or multi-

motor drives with traction-type couplings are used. A limited acceleration period is provided by the fluid coupling. Specially designed fluid couplings with coolers are fitted to keep the starting torque under the fully loaded conveyor conditions to a low level. NCB Specification 625 flameproof gate-end box starters up to 112 kW rating and flameproof gate-end box starters at 1100 V may be used to supply this type of drive, but a more common arrangement is either 3.3 kV or 6.6 kV flameproof direct-switching vacuum starters supplying higher rated flameproof motors.

The conveyors are started remotely via a telemetry data transmission link from the surface control room. The high-voltage flameproof starters can be fitted with additional auxiliary equipment to provide, for example:

- (1) manually controlled electrical loop-winch take-up facilities, used for the higher belt tensions and for accommodation of greater amounts of belt associated with longer conveyors;
- (2) integral contactors included in the control gear at 550 V for disc or drum brakes fully interlocked with main drive motors;
- (3) forward reverse contactors included in the control gear at 110 V or 550 V for electrically inserted scoop controlled fluid couplings, the arrangement allowing the main motors to be started first, and for separate insertion of scoops to provide drive to the belt; and
- (4) electrical controls for acceleration-torque-limit control (ATLC) fluid couplings, which incorporate a separate hydraulic power pack unit for insertion of scoops at a pre-set rate.

Steel-cord belting is used for some drift belt installations and where drive arrangements are similar to those described for main trunk roadway conveyors, utilising ATLC fluid couplings. Microprocessor techniques have been successfully used to control and limit the torque to 150% full-load torque during start-up and acceleration.

At the Prince of Wales colliery in North Yorkshire, the second longest belt conveyor in the UK is installed. Powered by a single 2240 kW drive unit, the 1706 m conveyor is the sole underground-to-surface conveyor at the mine. Coal is transported to the surface at a rate of 1000 t/h. The vertical lift is 334 m. The conveyor is designed to operate 24 h per day, with an annual operating time of 4500 h. It is capable of an annual tonnage of 2 million t and the system has the capacity to be extended to a 3000 m length.

The Selby Project (the development of an integrated mine with a capacity of 10 million t/year from five mines) utilises two drift conveyors each capable of dealing with the whole mine's output. The conveyor in the South Tunnel is 14 800 m in length with a total lift of 1000 m. The belting is steel-cord type SC7100, 1.3 m wide, with a rated breaking strength of 9054 kN (923 t). The conveyor drive is a single 2.67 m diameter drum powered by two direct-coupled thyristor controlled BCC type 'E' rationalised winder motors providing an available input to the belt of 10 MW. The speed will be variable up to a maximum of 8.4 m/s (1650 ft/min) and the conveyor is capable of delivering a maximum 3276 t/h at the surface. The conveyor in the North Tunnel is a cable belt conveyor and has duties similar to those of the South drift conveyor. The conveyor is 14 923 m long, with a maximum lift of 1000 m. The drive consists of twin 6.7 m diameter friction wheels driven by two thyristor controlled type 'D' rationalised winder motors via differential and single reduction gears. Available power input to the drive is 8.3 MW.

With the introduction of multiplex data transmission equipment and computer controlled coal clearance systems, a much wider range of FLP and IS sensors is now used to protect the conveyor. The range of sensors includes protection against belt slip, motor overheat, belt misalignment, bearing overheat, blocked chute, torn belt, brake overheat and limit switches for brake and scoop 'on' and 'off' proving.

48.4.1.1 Bunkers

Underground horizontal storage bunkers of the moving-belt and moving-car type with variable speed outfeed metering conveyors are used extensively for capacities up to 500 t. The BCC bunker automation system is now fitted to bunkers of 100 t and over to provide local/remote bunker infeed/outfeed control, using a capacitance probe system, bunker contents and bunker position facilities.

Staple shaft bunkers mounted vertically in the seam incorporating variable speed thyristor controlled outfeed vibro-feeders are used for large coal storage facilities up to 1000 t.

48.4.2 Rope haulage

Underground steel wire rope haulage systems employ vehicles running on (conventional) two rails or, alternatively, on single or double captive rails and a limited use of overhead monorail, for the transport of men and/or materials, with operating speeds of 1.61–32 km/h.

The prime mover of the haulage engine is usually a cage or a slip-ring induction motor with a range of 7.5–375 kW at voltages of 550, 1100 and 3300 V three-phase 50 Hz. The electrical equipment would normally be certified flameproof to Group I requirements.

Motors up to around 75 kW are generally started direct-on-line with a 'soft start' feature provided by a fluid coupling of traction or scoop type, although some 10–50 kW designs use a manually operated friction clutch. Also used are electrical devices which control acceleration by automatically increasing frequency and voltage from zero.

The larger machines use slip-ring motors having FLP rotor resistors and drum-type controllers to provide a variable speed drive. Another speed control for motors of 120 kW and above is the cycloconverter, which uses a thyristor converter controlled by a signal to give a varying frequency/voltage output to supply a purpose-designed cage motor.

Generally haulage systems are operated manually from a position local to the haulage engine, with a guard travelling with the vehicle(s) (either riding or walking) to stop and start the system via hardwire transmitted signals presented in audible and visual form to the operator. For higher speed haulages (above 8 km/h) the BCC type 986 Radio System, which operates on the 'leaky feeder' principle for transmission, is used for signalling from the travelling guard to the haulage engine operator.

For small ratings only, transporting haulages are operated by a man walking with the vehicles, from frequently spaced key operated hardwired connected switches, controlling forward or reverse and brake operating contactors. Because of the unattended (i.e. remote operated) haulage, the system must comply with requirements additional to those of conventionally operated haulages to obtain exemption from mining legislation, which normally requires an operator to be in attendance at the haulage engine.

The BCC type 986 Radio Communication System has been extended to provide control, by a travelling guard, of the speed and direction of the vehicles, in conjunction with the cycloconverter drive. The control transmission uses a coded address binary-function digital signal to switch specific function relays of the haulage drive control system.

48.4.3 Locomotives

In most modern mines the coal is transported from the coal-face to the shaft bottom by belt conveyor. There are, however, some mines where the coal is conveyed from the coal-face to an inbye loading point, where it is loaded into 4–5 t mine cars.

From the inbye loading point a train of mine cars will be hauled to the shaft bottom by either diesel, battery or trolley locomotives. These are currently 75 kW diesel locomotives and battery locomotives ranging in size from 6 t, 22.5 kW up to 40 t, 70 kW.

The larger battery locomotives are powered by a 100-cell 550-A-h lead-acid battery with a nominal voltage of 200 V. The battery is contained in a large robust ventilated steel container located in the centre of the double-ended locomotive (Figure 48.7), the battery weight being about 4 t.

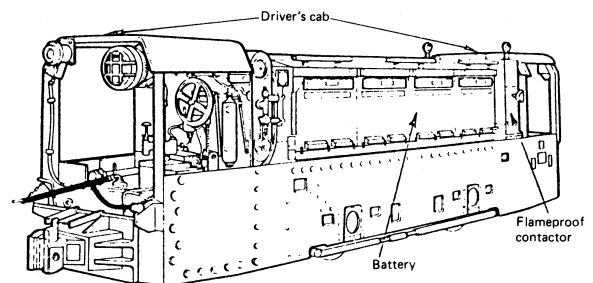

Figure 48.7 Battery locomotive

When a battery change is required, the locomotive enters the battery-charging station and positions itself between a pair of charging racks. The batteries are mechanically connected by the use of specially designed links and a racking device is set in motion. The discharged battery is racked onto the empty rack and the charged battery onto the locomotive, the whole process being completed in a few minutes.

Because the large lead-acid batteries on underground locomotives give off large quantities of hydrogen during the charging process, special requirements are laid down (Locomotive Regulations) governing the design of battery-charging stations. One of the principal requirements is that charging apparatus must be located on the intake side of the battery-charging racks and that ventilation air, having passed over the batteries, is directed into a return airway and does not subsequently ventilate a working face.

Storage battery locomotives for general use underground in coal mines are required by the terms of the Locomotive Regulations to be of a type 'approved by the Authority'. 'Health and Safety Executive—Testing Memorandum TM12' details the test and approval requirements. All electrical equipment used on storage battery locomotives, with the exception of the battery, is required to be certified flameproof.

Most locomotives have two driving motors, one on each of two sets of driving wheels. Series motors are employed with the armatures directly coupled to the driving wheels. Each motor is equipped with a bank of grid resistors controlled through a flameproof contactor and a speed controller. Each driver's cab is equipped with a speed controller, the two electrically interlocked to ensure that only one controller is in operation at any one time.

New locomotives incorporate thyristor chopper control, and methods are being devised to convert some of the existing locomotives to this form of control.

Most battery locomotives in mines are fitted with a battery leakage monitoring device, which consists of an electronic detection unit connected to the battery and an audiovisual alarm unit mounted in the driver's cab. The detector unit has a selector switch which allows the sensitivity at which the unit operates to be varied, a feature necessary to take account of the varying conditions under which the locomotives operate.

Four settings are available, giving battery leakage resistance values of 0.8, 1.3 and 2.6 k Ω . Operation of the alarm indicates that a fault has developed on one pole of the battery and that remedial action should be taken before a second fault develops on the other pole and sets up dangerous circulating currents.

Battery fires underground in coal mines are particularly dangerous and extremely difficult to extinguish once initiated.

Within the UK, trolley-wire locomotive installations have been tried in the past 30 years, but the system has not found universal acclaim, owing principally to the fact that the operating area of the locomotive is restricted to that covered by the trolley wire.

No statutory regulations exist covering the use of trolley locomotives underground in coal mines; consequently, when such installations are considered, special regulations are drawn up to suit each installation.

As coal-faces recede further from the shaft bottom and the need for increased efficiency demands quicker transport of men, materials and minerals to and from the coal-face, the advantages of trolley locomotives in certain circumstances have caused the BCC to look at further trolley installations. One such installation is currently operating on a single overhead 500 V d.c. conductor rail-return system, at a distance of 7 km from the shaft bottom, subsequently extending to 10 km.

Work is currently being undertaken on the design and development of a trolley/battery locomotive which will have complete shaft-bottom to coal-face capabilities, a distinct advantage over trolley systems. It is envisaged that the new trolley/battery locomotives will be rated at 20 t/120 kW, consisting of four 30 kW motors, and incorporating a 250 V, 500 A-h lead-acid battery capable of giving a 75 kW output over a 5-h period. The locomotives will operate on a twin 250 V overhead conductor system, and battery charging will take place while the locomotive is drawing power from the trolley wire. On reaching the end of the trolley wire the locomotive will change to battery power and will carry out excursions away from the trolley area.

The speed at which trolley locomotives operate is 15–20 km/h, compared with the 10–12 km/h of conventional diesel or battery locomotives. With improvements in roadway conditions and better standards of track, speeds of 30 km/h can be expected.

48.5 Coal-face layout

When a new coal-face is started, two roadways are driven from the main intake and return roadways, to form the intake (main gate) and return (return gate) roadways for the coal-face. In each roadway a 6.6 kV DWA PVC three-core aluminium 185 mm² roadway cable is installed. This supply is obtained from a local substation which, in turn, obtains its supply from the pit-bottom substation via the parallel district feeders. The main and return gate roadway cables are supported on special hangers attached to the roadway arches at approximately 2 m spacing. These are adequate to support the cable but, in the event of a roof fall, the additional weight causes the cable supports to give way and allows the cable to fall to the floor.

Each roadway cable terminates into a 6.6 kV flameproof 400 A, 150 MV-A circuit-breaker incorporating overcurrent, earth leakage and short-circuit protection. This breaker is a semi-permanent unit, being moved up periodically by the insertion of 100 m of roadway cable as the coal-face advances (*Figure 48.8*).

Advancement of the h.v. circuit-breaker and armoured roadway cable is always carried out with all power isolated, as opposed to all other equipment (flexible wire armoured cables, transformers, contactors, etc.), which is advanced automatically by hydraulic power as the coal-face advances.

From the h.v. circuit-breaker a 6.6 kV, 50 mm² flexible pliable wire armoured (PWA) cable takes the h.v. supply to a flameproof transformer. The PWA cable is supported in loops from a monorail attached to the crown of the roadway arches. Special cable supports with rollers permit automatic advancement.

Flameproof air-cooled transformers are used underground. Common ratings in use are 500, 750 and 1000 kV-A; they weigh about 5 t.

To permit automatic advancement, the transformer, hydrostatic power pack, flameproof contactors (gate-end boxes) and face signal/communication unit, along with spares container, oil drums, stretchers, first aid and fire fighting equipment, etc., are mounted on a robust rail-mounted pantechnicon which straddles the main roadway conveyor. The pantechnicon is securely attached to the stage loader conveyor, which, in turn, is attached to the coal-face armoured flexible conveyor (AFC).

As the coal is cut by the power loaders, the AFC is pushed forward by hydraulic rams attached to the hydraulic roof supports. This action causes the stage loader (AFC) to advance forward, which, in turn, automatically advances

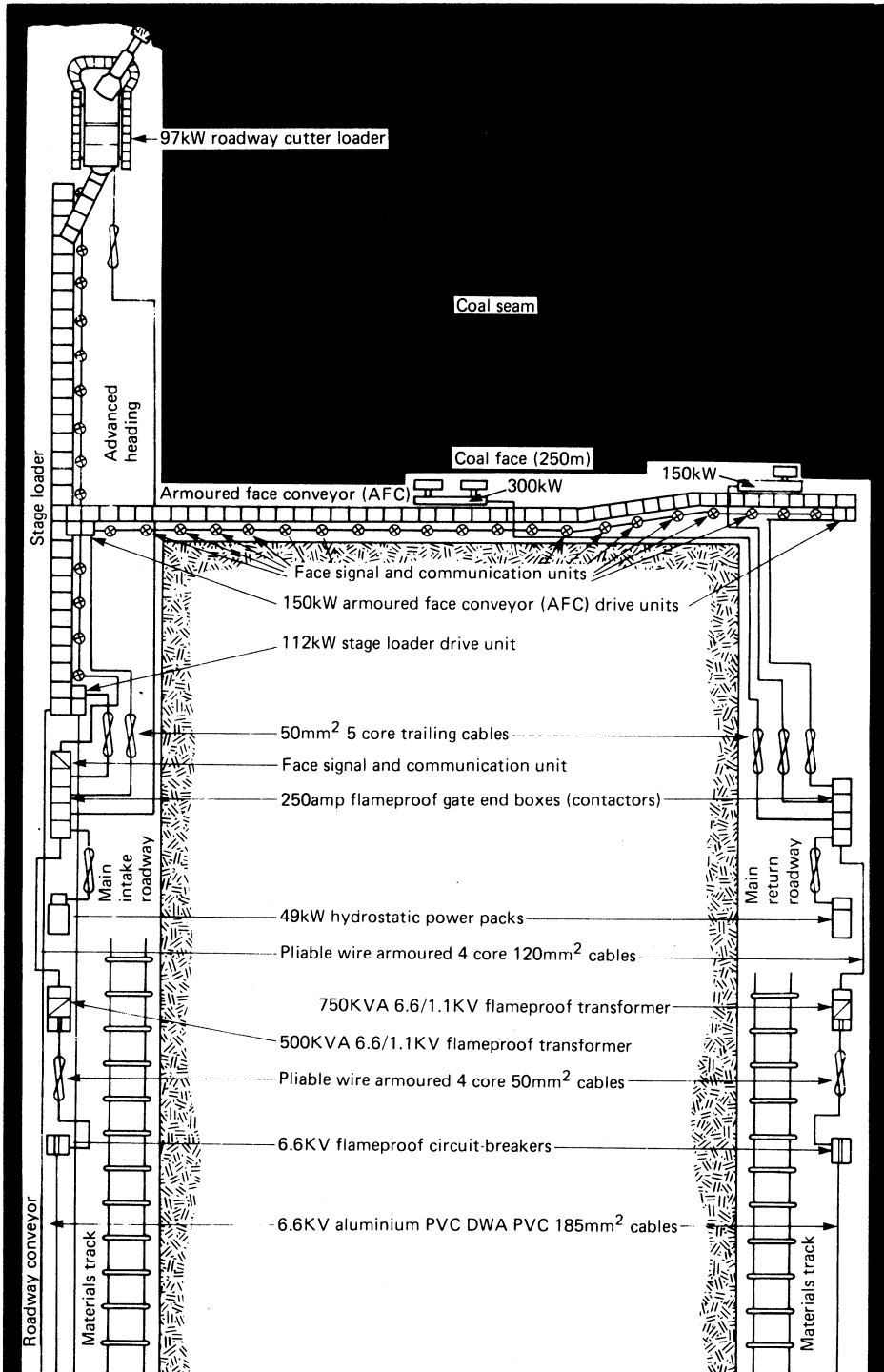

Figure 48.8 Layout of a typical 250 m coal-face

the pantechnicon. When the h.v. PWA cable has been fully extended, power is isolated, allowing the h.v. circuit-breaker and PWA cable to be moved forward, and a new length of 185 mm² aluminium PVC-DWA-PVC roadway cable to be installed.

Armoured roadway cables are installed in 100 or 200 m lengths and are sent into the mine already fitted with 300 or 400 A flameproof cable couplers, which are normally connected on site with copper connecting pins, rubber gasket, bolts and nuts.

PWA 120 mm² four-core cable is used to take the m.v. 1100 V supply from the transformer to the bank of flameproof contactors (known in the industry as gate-end boxes). Each gate-end box (Section 48.9) is equipped with a 200 A flameproof restrained plug and socket which permits supply to the machine via a 50 mm² five-core trailing cable. These cables pass along the side of the stage loader to the machines on the coal-face. The static parts of power-loader trailing cables are located in specially designed cable troughs attached to the AFC, whereas the part of the trailing cable which flexes backwards and forwards as the power loader moves along the coal-face is contained in a robust flexible steel or plastic cable handler. Such handlers also contain a water hose which supplies the machine with water for dust suppression and motor cooling. A typical coal-face could be established as in *Figure 48.8*.

The right-hand single-ended ranging drum shearer (SERDS) cuts the right-hand end of the face to a distance of about 25–30 m, while the main machine, the double-ended ranging drum shearer (DERDS) cuts the rest of the face.

Attached to the bank of gate-end boxes in the main gate is a flameproof and intrinsically safe face signal and communication unit. Connected to this unit and spaced approximately every 7 m along the stage loader and coal-face conveyors are face signal and communication units. Each unit is equipped with a signal push-button and lock-out stop key, and every third or fourth unit incorporates a loudspeaker and microphone.

A control point attendant at the face signal and communication unit position controls the stage loader and face conveyor in response to signals transmitted by any of the signal pushbuttons. Upon operation of the start button for the stage loader (which, in turn, automatically starts the face conveyor) a seven-second pre-start warning two-tone 'bleep' is transmitted along the whole length of the stage loader and face conveyor, warning faceworkers that the conveyors are about to start.

Operation of a lock-out push-button causes the respective conveyor to stop. Should this conveyor be the stage loader,

the face conveyor will also stop, as they are connected in sequence.

Should the lock-out push-button be latched in the lock-out position, the conveyor cannot be started until that push-button has been reset. Each lock-out push-button has a specific number which is automatically displayed by a digital readout on the face signal and communication unit whenever a particular lock-out is operated. By the use of such communication facilities, the cause, necessary remedial action and subsequent duration of a stoppage in production can be quickly ascertained.

The face signal and communication unit is connected by cable to the main colliery control room on the surface, which permits instant and direct communication between the surface control room and any point along the working face, or vice versa.

Each power loader is controlled by an individual operator, sometimes by using radio control. Before the machine can be started, water must be turned on to the pre-start warning water jets positioned on either side of the cutting drum. This condition must persist for approximately 7 s before power can be switched on to the machine, thereby warning by wetting anyone inadvertently in a dangerous position that the machine is about to start.

48.6 Power loaders

The modern coal-getting machine is termed a 'power loader' because it not only cuts coal, but also loads it onto the armoured flexible conveyor (AFC), which is, in effect, a steel scraper conveyor running the full length of the working face. *Figure 48.9* illustrates a typical modern power loader which has a rotating cutting disc at each end of the machine, mounted on a ranging arm to cater for thicker seams of coal which could be 2–3 m or more. This type of machine is known as a double-ended ranging drum shearer (DERDS). Certain methods of mining call for the use of a machine with only one cutting disc. Such a machine, similar to that illustrated, is termed a single-ended ranging drum shearer (SERDS).

The majority of power loaders are driven by a single 150 kW motor, operating at 1100 V. Some larger machines, however, have been developed using a single 300 kW motor or a two 300 kW motor arrangement. The supply is obtained from a gate-end box in the roadway via a flexible trailing cable, which on the coal-face is enclosed in a robust flexible cable handling device for protection.

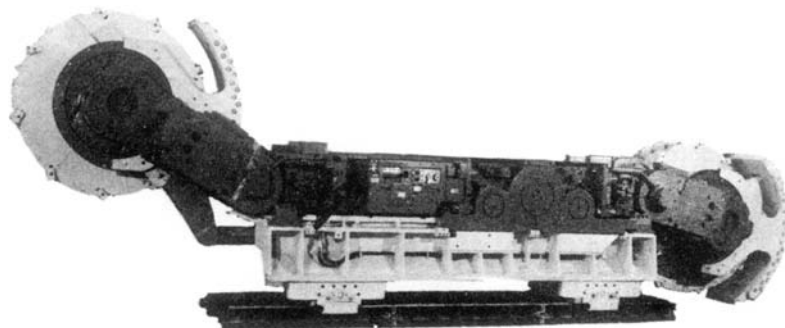

Figure 48.9 Power loader

Each complete machine is built up of a number of sections, consisting basically of electric motor, haulage unit and gearhead.

Incorporated in the motor are a reversing isolator, control facilities and fault diagnostic equipment, which are connected to the flexible cable by a flameproof plug and socket. A drive shaft protrudes from each end of the motor to transmit power to the adjacent units.

The motor at one end is attached to the haulage unit, which provides the hydraulic power, to haul the machine along the coal-face via a driven pinion on the machine, and a static rack attached to the AFC. Speed control is automatic, following the limits determined by the operator who travels with the machine.

Attached to the opposite end of the motor (single-ended machine) is a gearbox, which drives the rotating coal cutting disc. In a double-ended machine a similar gearbox is attached to the haulage unit at the opposite end of the machine.

Radio control techniques have been developed for power loaders, which allow the operator to control the machine from a comparatively safe area, some 15–20 m from the machine.

48.7 Heading machines

One of the principal requirements of modern mining is the ability to drive roadways quickly and safely. This is achieved in the main by the use of heavy-duty roadway cutter loaders (*Figure 48.10*). These machines are equipped with one or two rotary cutting heads, which cut out the stone and shape the profile of the roadway to 4 m × 3–5 m.

Debris from the cutting heads falls onto a rotary scraper conveyor at the front of the machine, which transfers the cut material to a bridge conveyor at the rear of the machine, and then on to the roadway conveyors (*Figure 48.8*).

Roadway machines are fed by flexible trailing cables at 1100 V and typically have a 50 kW motor driving a hydraulic power pack and a 50 kW motor driving each cutting head. The machine traverses on hydraulically powered caterpillar tracks, the whole machine being controlled by an operator sitting in the middle of the machine.

48.8 Flameproof and intrinsically safe equipment

During the process of extracting coal from the seam, methane gas is given off. It combines with the normal mine air flow and is eventually disposed of at the surface of the mine through the mine ventilation system. By this means the methane content in the mine air is kept to low and safe proportions.

Owing to possible malfunctioning of ventilation apparatus, power supply failure or heavy emissions of methane, the methane/air ratio can increase. Between approximately 5 and 15% methane to air, the mixture becomes explosive, the most explosive mixture being 8.3% methane to air. Electrical equipment in which sparking during normal operating may occur is capable of igniting an explosive methane/air mixture and must, therefore, be given special consideration. For equipment operating at a low voltage and current levels, the circuits can be designed such that the energy released at the spark is insufficient to cause ignition. This can be achieved by the use of non-inductive resistors, non-linear resistors, capacitors, shunt diodes, Zener diodes, full-wave rectifiers, etc., to give 'intrinsically safe' (IS) apparatus.

Apparatus classed as 'intrinsically safe' includes telephones, signals, communications, testing instruments, methanometers, sensors and remote control and monitoring. Since any open sparking produced within such equipment is incapable of igniting an explosive methane/air mixture, no other form of protection is required other than to house the components in a robust enclosure.

In the UK, it has been the practice to design IS apparatus to conform to the requirements of BS 1259 (IS Electrical Apparatus and Circuits). Equipment now, however, is designed to the CENELEC Standard, now BS 5501: Part 7.

IS equipment must be certified by an approved certifying authority for use in mines and the IS certificate number along with other specified information must be clearly marked on each item.

One of the principal requirements of the intrinsically safe certificate is that the equipment must be supplied from an approved source of supply, which can be either a.c. or d.c. The current British Standard covering such supplies is BS

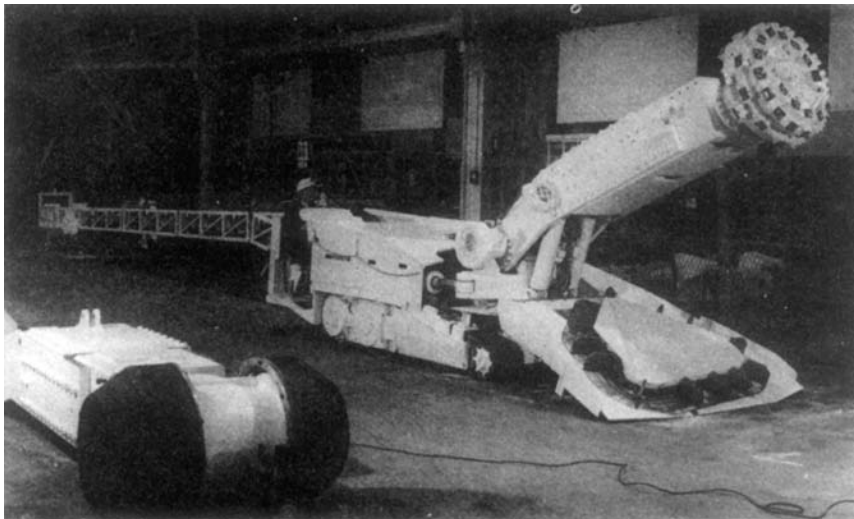

Figure 48.10 Boom miner with bridge conveyor

6182 (Intrinsically Safe Power Supplies) and caters for a.c. and d.c. supplies and rechargeable battery units.

There are three categories of d.c. supplies, i.e. 7.5, 12 and 18 V, and two of a.c. supply, i.e. 12 and 15 V. Rechargeable batteries of 8 and 14 V are specified, each capable of being charged from the respective source of supply, i.e. the 8 V battery from the 12 V d.c. supply and the 14 V battery from the 18 V d.c. or 15 V a.c. supply.

Power equipment operating on higher current levels which produce sparks during normal operation, and which cannot be designed to be intrinsically safe, must be enclosed in a robust enclosure. If an explosive methane/air mixture exists in a mine roadway and enters the apparatus containing spark producing components, the flame resulting from the ignition will not be transmitted to the ambient atmosphere and so ignite the general body of the mine air. The enclosure in which spark producing components are housed is termed a 'flameproof enclosure'.

Equipment coming within this category covers such items as motors, contactors, switchgear, transformers, light fittings, plugs and sockets, cable couplers, etc., and requires to be certified flameproof by the approved certifying authority as safe for Group 1 gases (methane). In the past, the relevant British Standards were BS 229 and BS 4683. Equipment now, however, is designed to comply with the CENELEC Standard, now BS 5501: Part 5.

A 'Flameproof Certificate' is issued, the number of which must be permanently displayed on each item of equipment along with other relevant details required by the Standard, i.e. manufacturer's name, type reference, number of British Standard, etc.

The harmonisation of European Standards resulted in the issue in 1977 by CENELEC (European Committee for Electrotechnical Standardisation) of the EN 50 series of standard, i.e. EN 50-014 to EN 50-020 Electrical Apparatus for Potentially Explosive Atmospheres. Equipment designed and certified to this standard is accepted by the European Community without further testing, etc.

The European Standards of 1977 were issued as British Standards: a list is given in *Table 48.1*. Since then, these Standards have been periodically updated and two further Standards have been issued, i.e. CENELEC Standard EN 50028 Encapsulation type 'm', i.e. BS 5501: Part 8, and Cenelec Standard EN 50039 (IS) systems, i.e. BS 5501: Part 9.

Gaps associated with any removable covers, doors, motor shafts, etc., must conform to minimum dimensions laid down by the standard. 'Flameproof' apparatus must be designed, installed and maintained at all times within those limits. As a typical example of the tolerances permitted, gaps with a length of 12.5 mm must not exceed 0.4 mm and for 25 mm flanges the maximum is 0.5 mm. During

normal maintenance procedures in the mine these gaps are periodically checked by colliery craftsmen using feeler gauges.

48.8.1 Flameproof transformers

Providing sufficient electrical energy at the modern coal-face with a demand of some 1–1.5 MV-A at a distance of 6–8 km from the shaft bottom and at a depth of 900–1000 m requires an efficient h.v. electrical distribution system.

From the voltage regulation point of view it is essential that the h.v. supply be taken up to the working face, therefore transformation facilities are needed to provide the coal-face utilisation voltage of 1100 V.

Before the advent of flameproof dry-type transformers, standard industrial oil-filled transformers were utilised, often with flameproof oil circuit-breakers attached to each end. Mining legislation at that time, however, decreed that such transformers could not be used nearer than 300 yards from the coal-face and in no circumstances could they be used in a return roadway. As coal-face loading increased in the 1950s and early 1960s as a result of the mechanisation of coal-getting, it became of paramount importance to move the transformer right up to the working face and strengthen the h.v. distribution system. This led to the development of the flameproof air-cooled transformer, which has a flameproof h.v. circuit-breaker on the h.v. side and a flameproof m.v. chamber mounted on the opposite end to house the overcurrent, sensitive earth leakage and short-circuit protection equipment, which on operation causes the h.v. circuit-breaker to trip. Typical transformer ratings would be 500, 750 and 1000 kV-A. Comparing these with the old oil-filled types (which were usually of the order of 250 kV-A) indicates the change which has taken place in the mining industry since nationalisation in 1947.

Figure 48.11 shows a typical 750 kV-A flameproof transformer viewed from the h.v. end, the circuit-breaker being a 6.6 kV, 400 A, 150 MV-A sulphur hexafluoride (SF₆) unit complete with incoming cable adapter suitable to accept the 6.6 kV, 300 A, six-bolt cable coupler attached to the end of the incoming 6.6 kV h.v. cable. The m.v. chamber at the opposite end is approximately three-quarters the size of the h.v. circuit-breaker and is similarly equipped with flameproof adapters to accommodate the outgoing 1100 V cables.

The transformer is equipped with lifting lugs for loading and unloading and adjustable wheels for transportation underground. The total weight would be of the order of 5–5½ t.

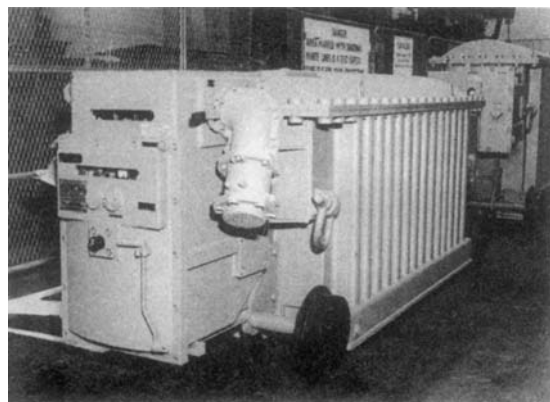

Figure 48.11 Flameproof transformer

Table 48.1 Standards for electrical apparatus for use in potentially explosive atmospheres

<i>CENELEC Standard, EN 50-</i>	<i>British Standard BS 5501</i>	<i>Subject</i>
014	Part 1	General requirements
015	Part 2	Oil immersion 'o'
016	Part 3	Pressurised apparatus 'p'
017	Part 4	Power filling 'q'
018	Part 5	Flameproof enclosure 'd'
019	Part 6	Increased safety 'e'
020	Part 7	Intrinsic safety 'i'

48.8.2 Flameproof switchgear

Prior to the mid-1960s, nearly all the h.v. and m.v. circuit-breakers used in mines were of the oil-break type, usually of the order of 150/200 A, 3.3 kV, 25 MV-A and, although certified flameproof, they constituted a hazard owing to the oil-fire risk. In addition, maintenance of the oil was a problem due to the oil transport and cleanliness, and the disposing of waste oil. With the introduction of no-oil switchgear, maintenance was reduced and the oil-fire risk eliminated.

Modern flameproof mining-type circuit-breakers operate on either the air-break, vacuum interrupter or sulphur hexafluoride gas principle and can be arranged such that they can be utilised as single free-standing units, on a complete switchboard, or mounted on the h.v. end of a flameproof transformer.

Owing to the increase in demand for electrical power underground and the uprating of underground distribution systems, switchgear ratings have also increased. A typical modern flameproof circuit-breaker as shown in *Figure 48.12* would be a 6.6 kV, 400 A, 150 MV-A unit. This circuit-breaker is of the vacuum interrupter type and the illustration shown is a classical example of the construction of flameproof switchgear. The flameproof enclosure is divided into separate flameproof compartments electrically linked by the use of flameproof bushed terminals. In the bottom compartment the circuit-breaker is housed on a withdrawable chassis complete with overcurrent, earth leakage and short-circuit protection.

Two separate compartments are provided in the centre of the circuit-breaker which accommodate the isolator(s) and incoming or outgoing cable terminations. Also incorporated in the section are the isolator and circuit-breaker operating handles, which are mechanically interlocked

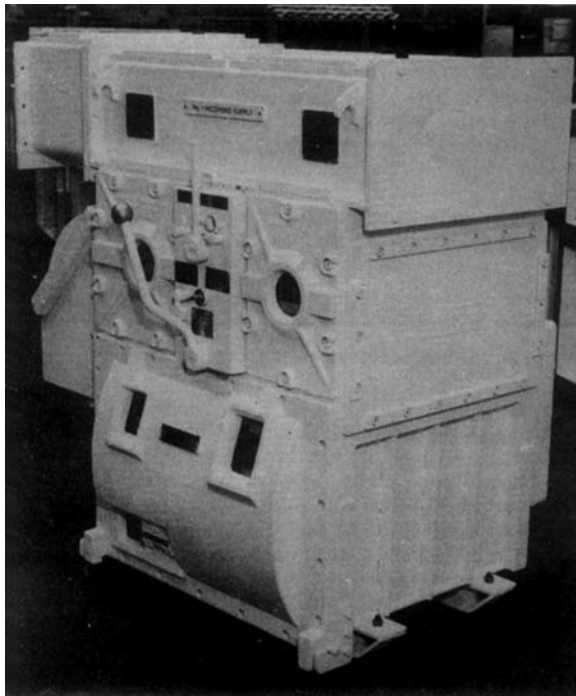

Figure 48.12 Flameproof circuit-breaker

to ensure that the isolator can be operated only with the circuit-breaker in the 'off' position. Mechanical interlock is also provided between the isolator and circuit-breaker handles and the front cover of the circuit-breaker compartment, to prevent access until the interior has been made dead.

With slight modification to the basic design, flameproof mining-type circuit-breakers can be used in either of four different modes, i.e. incoming unit, feeder unit, bus-section unit or transformer switch unit.

48.9 Gate-end boxes

The control of individual drives in a coal mine, such as conveyors, power loaders, pumps, haulages, etc., is achieved as in any other industry, i.e. by use of contactors.

For mining purposes contactors must be enclosed in a robust flameproof enclosure or box. In the early days of electricity in mines, such a box would be installed at the end of the roadway leading to the coal-face. To use mining parlance, a roadway is a 'gate'; therefore, the 'box' installed at the 'gate end' became known as the 'gate-end box'.

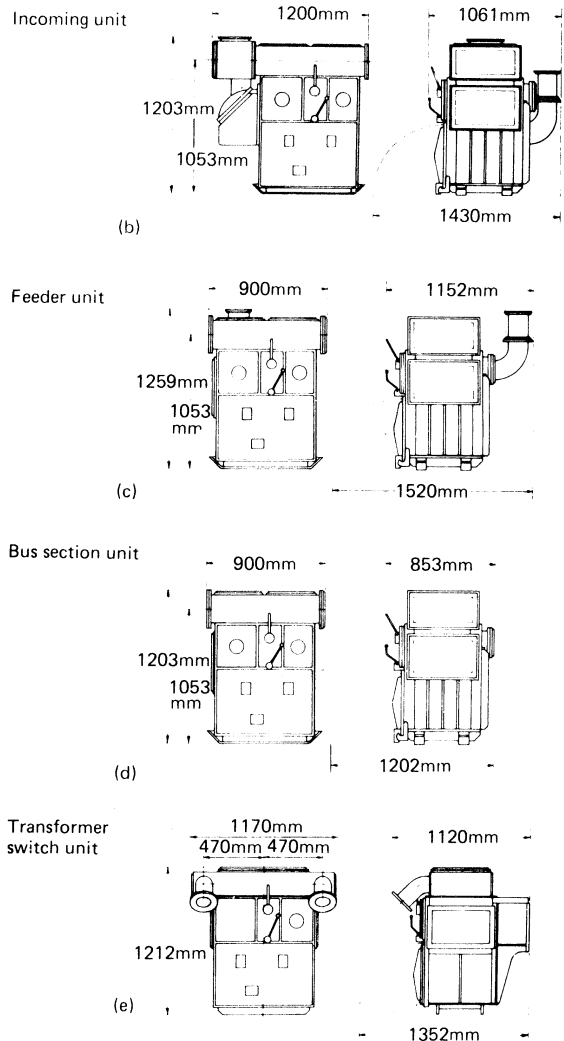

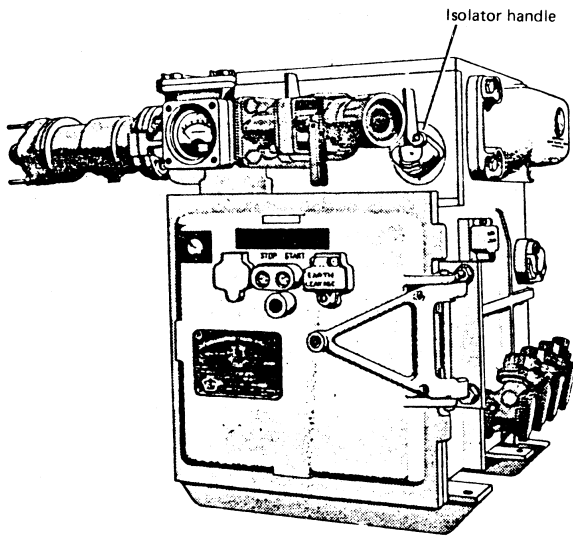

Figure 48.13 Gate-end box

The term is still used today to refer to a flameproof contactor unit.

Figure 48.13 illustrates a typical flameproof gate-end box suitable for use on an 1100 V, three-phase, 50 Hz system, and rated at 300 A. The box can be adapted for use as a single unit or assembled to form a 'bank of panels'. Figure 48.14 shows a typical bank of panels mounted on a pantech-nicon over a roadway conveyor adjacent to a coal-face.

A gate-end box consists of upper and lower chambers interconnected by flameproof bushed terminals. The upper compartment contains 400 A throughgoing bus-bars and a three-phase isolator. The ends of the bus-bar chamber are designed to accept flameproof bus-bar trunking units and links to enable individual panels to be built up into a bank or to accept a bus-bar blank at one end and an incoming

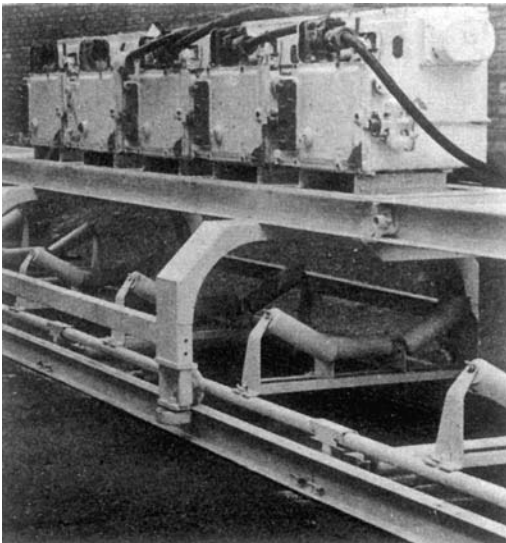

Figure 48.14 Bank of gate-end boxes

cable adapter at the other to form a single unit. In the lower compartment is housed the contactor of rating 150, 250 or 300 A, and a control unit, all mounted on a removable chassis for ease of maintenance, repair or removal.

A mechanical interlock is provided between the isolator operating handle and the contactor compartment cover to ensure that access to the contactor compartment is prevented until the isolator has been placed in the 'off' position.

Power is transferred to the drive from the gate-end box via a flexible trailing cable which, owing to the hazardous environment of the coal-face, is always susceptible to damage. Facilities must therefore be provided to enable the trailing cable to be changed quickly. This facility is provided on the gate-end box and the motor in the form of a 200 A restrained flameproof plug and socket (Figure 48.15).

Taking into consideration the control facilities, sensitive earth leakage protection, static overcurrent protection equipment, etc., the modern gate-end box is a complex piece of electrical equipment which has to work with a high degree of reliability in an atmosphere that can be hot, cold, dry, wet and, on occasion, subject to considerable vibration. Some of the electrical/electronic components can therefore be subject to abnormal abuse while in service. It is for this reason that the evolution of the modern gate-end box has resulted in the majority of the small electrical/electronic components being contained in a 'control unit', which is a plug-in unit on the contactor chassis. This control unit can be quickly changed in the event of trouble, and transported to the surface workshop for overhaul and repair.

Control of the gate-end box can be effected locally or remotely, the selection being by way of a changeover switch on the control unit. In the majority of cases the remote control facility is adopted: it utilises a pilot control core in the five-core flexible trailing cable and a flameproof starting device at the motor end. In the past, the pilot circuit or the remote control IS circuit was designed to the NCB specification P130, based on the following principles:

- (1) the circuit is energised from an intrinsically safe constant voltage transformer within the gate-end box, designed to give a constant 12 or 7.5 V secondary output over a wide variation of primary input—one side of the 12 or 7.5 V winding is earthed;
- (2) a pilot relay is provided in the gate-end box which will operate on half-wave but not on full-wave a.c.; and
- (3) at the far end of the trailing cable a diode is provided along with a start switch across which is connected a $30\ \Omega$ resistor.

With the upgrading of the specification for intrinsically safe (IS) equipment it has become difficult to design this

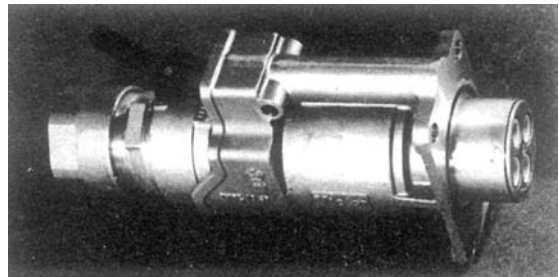

Figure 48.15 Flameproof plug and socket

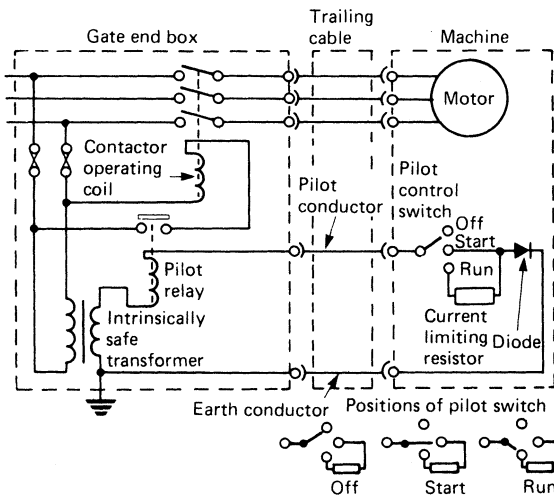

Figure 48.16 Contactor-coil/pilot circuit

pilot circuit to the latest IS requirements. A new British Standard (BS 7202: 1989 Non Incendive Low Voltage Control/Interlock and Low Voltage Earth Fault Monitoring Circuits for Use in Mines) has been issued to which the equipment is now being designed.

Figure 48.16 shows a basic arrangement of the contactor coil/pilot circuit within a gate-end box, the associated trailing cable and a face machine with in-built start switch. To start the machine, the switch is moved to the 'start' position. With only the diode in circuit the pilot relay (PR) energises and the machine starts. The start switch now reverts automatically to the 'run' position inserting the $30\ \Omega$ resistor into circuit.

Should a power failure occur with the control switch in the 'run' position, following which the power is restored, the relay PR will not energise at a voltage below 120% of the declared voltage of the incoming supply. Operation of the start button causes PR to energise: it must do so down to 75% of the declared incoming voltage supply. Once energised and with the $30\ \Omega$ resistor in circuit, PR must remain energised down to 60% of the declared voltage but under no circumstances continue to operate at 20% or below.

Should a damaged trailing cable result in a pilot core-to-earth fault, full-wave a.c. would be applied to PR which (on account of the increased impedance) would de-energise if in operation, or fail to energise upon operation of the start button. This condition, known as pilot core protection (PCP), would be indicated by a lamp at the front of the gate-end box.

Prior to 1959 most transformers used underground to supply coal-face equipment had the neutral point of the secondary windings solidly earthed, and earth leakage protection in gate-end boxes operated on the core-balance principle. Trailing cable damage on such systems resulted in very severe incendive arcing which, on the coal-face especially, was a very serious hazard. Following an explosion at Walton Colliery near Wakefield in 1959, H.M. Principal Inspector of Mines recommended that a further attempt should be made to devise an electrical protective system capable of eliminating, or at least substantially reducing, the dangers of incendive sparking resulting from damaged trailing cables. This led to the development of the sensitive earth leakage (SEL) circuit, which exists in two forms: single point and multi-point.

48.9.1 Single-point sensitive earth leakage

The basic principles of single-point earthing systems are similar to those of solidly earthed systems in that a core-balance transformer more sensitive than used on solidly earthed systems is employed. This system is sometimes referred to as sensitive core balance, and the main difference between the two systems is in the method of earthing the neutral point of the transformer secondary winding.

In the single-point system an impedance is inserted between the neutral point and earth of such value as to limit the earth fault current to a maximum of 750 mA (Figure 48.17). Although this is the maximum earth fault current permitted, individual earth fault trip circuits are set to trip at between 80 and 100 mA, giving a safety factor of approximately 7 to 1.

The core-balance transformer output under fault conditions is very small and an electronic amplifier is used to control the earth fault relay, which is energised under healthy conditions and de-energises on the occurrence of a fault. This arrangement results in a fail-safe system. The earth leakage relay contacts are inserted in the contactor coil circuit, which opens on the occurrence of a fault.

To ensure that a contactor cannot close onto a system on which an earth fault condition exists, an additional arrange-

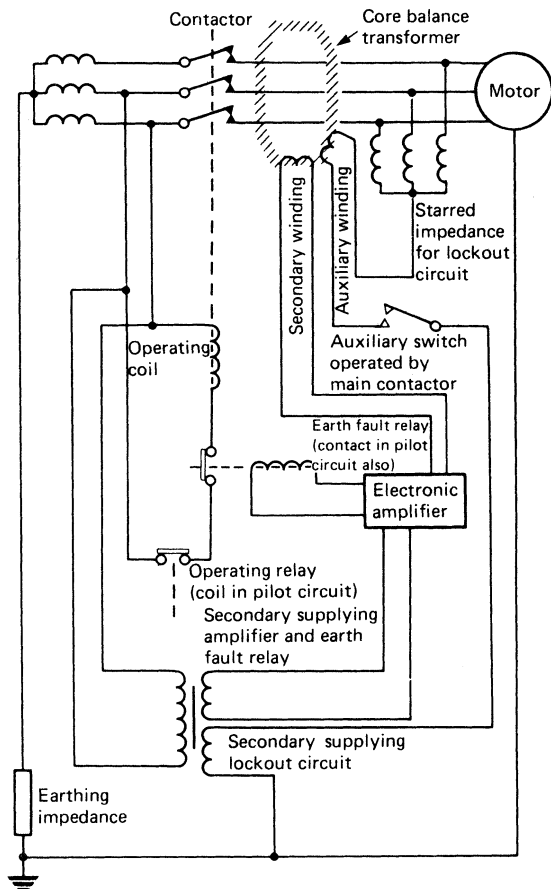

Figure 48.17 Protection unit for high-impedance single-point earthing

ment is provided which is termed the electric lockout circuit. It consists of three impedances, one end of which is connected to the three outgoing phases; the other ends are star-connected and, in turn, are connected to an auxiliary core-balance transformer winding, a pair of contactor auxiliary contacts (closed when the contactor is open) and an intrinsically safe source of supply which has one end of its winding earthed. Should an earth fault develop while the contactor is de-energised, the earth leakage lock-out circuit would operate to prevent the contactor coil energising, a condition that would persist as long as the earth fault was in existence.

48.9.2 Multipoint sensitive earth leakage

In the multipoint system the transformer secondary is completely insulated from the earth, i.e. it is a free neutral (*Figure 48.18*). Each contactor is provided with a false neutral which, similar to the single-point system, consists of three impedances connected to the three outgoing phases. The star point is connected via a pair of contactor auxiliary change-over contacts to either the failsafe earth leakage detection circuit or the earth leakage lock-out circuit, depending on whether the contactor is energised or not.

The earth fault current on the multipoint system is limited to 40 mA on a 1100 V system. Since an earth fault on a system supplied from one transformer could cause all gate-end boxes on the system to trip, and in order to keep the maximum earth fault current to 750 mA, the number of gate-end boxes on a system must be limited to $750/40 = 48$.

When a contactor trips on earth leakage on either system, that contactor locks out and displays earth leakage trip conditions, which can only be re-set by an authorised craftsman with the appropriate specialised equipment.

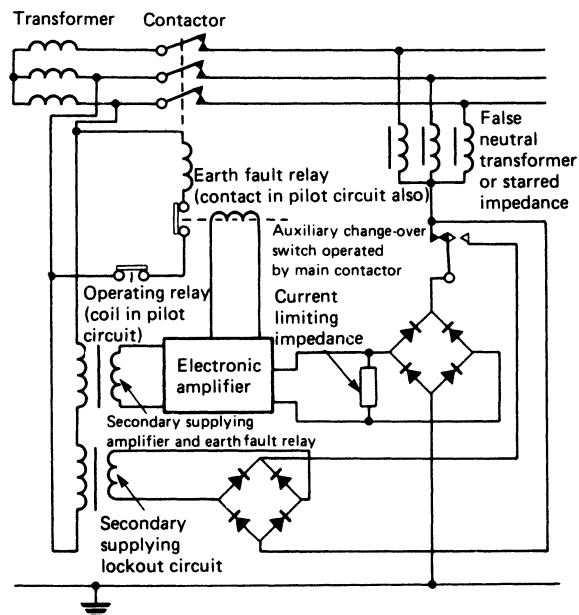

Figure 48.18 Protection unit for multipoint earthing

Table 48.2 National Coal Board (NCB) Specifications for flameproof motors

NCB Specification No.	Motor rating (kW)	Mounting	Voltage (kV)
291	37.5–50	Flange	≤1.1
420	67.5–90	Flange	≤1.1
542	2.25–30	Foot/flange	0.11–1.1
625	112	Flange	0.55–1.1
634	112	Flange	2.2–3.3*
635	112	Flange	2.2–3.3†
636	150	Flange	1.1
637	225	Flange	1.1
651	75	Foot	0.55, 1.1, 3.3‡←

*Single-stack conductors.

†Other than single-stack conductors.

‡For booster fans.

48.10 Flameproof motors

Mechanisation of the coal-mining industry in the 1950s, followed by further mechanisation and automation in the 1960s and 1970s completely changed the face of the industry. Elimination of 'self-generation' at collieries and the introduction of duplicate and more substantial power supplies from the Electricity Boards plus the strengthening of colliery distribution systems made the direct-on-line starting of large cage-induction motors possible. BCC Specifications have been produced covering the majority of FLP motors used in British mines (see *Table 48.2*).

Motors associated with coal-face equipment need changing more often than those operating in roadways and engine houses, owing to the hazardous conditions in which the equipment has to operate on the coal-face, physical damage and ingress of water moisture being the prime causes of failure. To facilitate speed and accuracy in changing and lining up, such motors are designed for flange mounting. *Figure 48.19* shows a typical flange-mounted motor complete with flameproof terminal box and flameproof 200 A plug and socket.

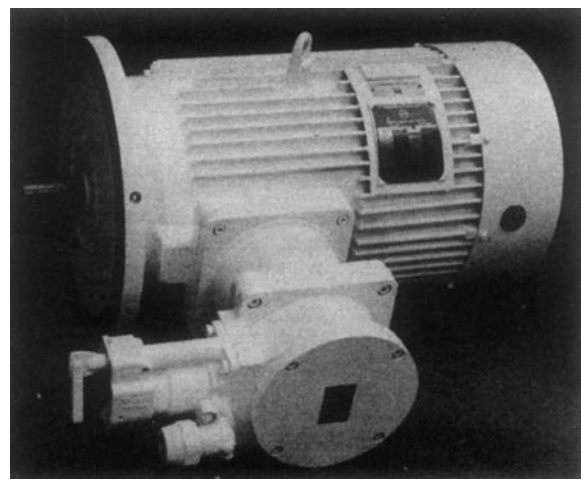

Figure 48.19 Flange-mounted flameproof motor

Table 48.3 National Coal Board (NCB) Specifications for cables

NCB Specification No.	Subject
P115	Short-firing cables (other than in shafts)
P188	Flexible trailing cables (for coal cutters and similar use)
P295	PVC-insulated wire armoured and sheathed cables
P492	PVC-insulated wire armoured telephone cables
P493	PVC-insulated wire armoured signalling cables
P504	Flexible trailing cables with galvanised steel pliable armouring
P505	Flexible trailing cables (for drills)
P610	Flame-retardant properties of flexible trailing cables
P648	Multicore PVC-insulated wire armoured and PVC sheathed 0.6–1.0 kV cables (with special screening for mine winder safety and control circuits)
P653	Flexible multicore screened auxiliary cables with galvanised steel pliable armouring
P656	EPR-insulated wire armoured and PVC sheathed cables

EPR, ethylene propylene rubber; PVC, polyvinyl chloride.

48.11 Cables, couplers, plugs and sockets

All cables used in mines for any purpose must conform to the requirements of the relevant BCC Specifications, which are listed in *Table 48.3*. Colliery surface and underground h.v. and m.v. distribution systems utilise, in general, PVC insulated and sheathed mains cables. DWA cables have up to a few years ago been exclusively used for underground systems but recently single wire armoured (SWA) cables have received favourable consideration, owing to reduced cost and flexibility in handling. Such cables conform to NCB Specification 295 or 656.

Wire armoured roadway cables are usually received at the colliery on 100 m drums with 300 A flameproof couplers already fitted at each end. On completion of assembly the cable coupler is filled with either bituminous compound or a cold-pouring compound, consisting of a bituminous oil and a hardener. A typical 6.6 kV, 300 A flameproof cable coupler is shown in *Figure 48.20*, the halves being connected by the use of three connector pins, a rubber sealing gasket and six connecting bolts.

Mobile machines such as power loaders and roadheading machines, which require to move while energised, must be powered by the use of a flexible trailing cable to satisfy the requirements of NCB Specification 188. Several types are available, ranging in size from 16 to 95 mm². *Figure 48.21* illustrates a typical trailing cable (type 7). It consists of three power cores, a pilot control core and an earth core. The earth core is uninsulated, and is located in the centre of the cable, with the three power cores and the pilot core equally spaced around it. All four cores are insulated with ethylene propylene rubber (EPR); the power cores have an additional copper/nylon screen over the insulation. Overall protection is provided by a tough heavy-duty polychloroprene (PCP) oversheath. A similar cable but of slightly different

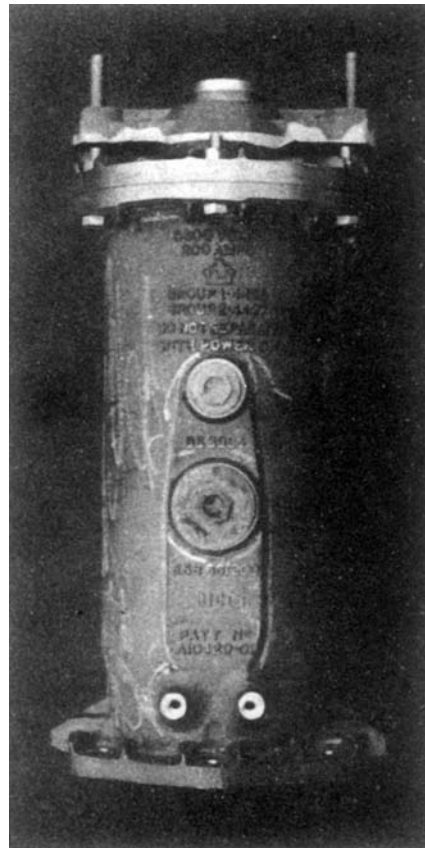

Figure 48.20 Flameproof cable coupler

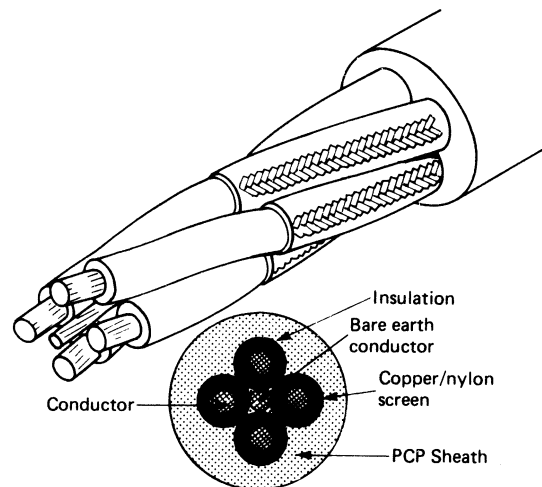

Figure 48.21 Trailing cable (type 7)

construction is the type 10 cable shown in *Figure 48.22*. The three power cores and pilot core are again EPR insulated, but each has a conductive rubber screen, and all four cores are laid up around a conductive rubber cradle separator. The overall protective sheath is PCP.

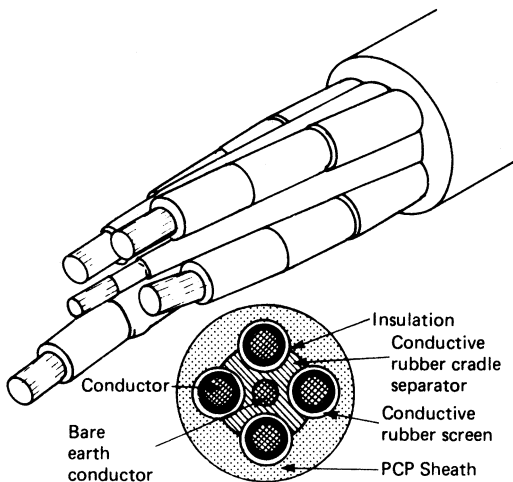

Figure 48.22 Trailing cable (type 10)

Since trailing cables associated with mobile machines are susceptible to damage, means must be provided to quickly connect or disconnect the cable from the motor/gate-end box. This facility is provided in the form of a 200 A, 1100 V flameproof restrained plug and socket, a typical example of which is shown in *Figure 48.23*. The socket is attached to the motor/contactors and the plug is attached to the cable. A scraper earth facility is provided on the socket which mates with the nose of the plug as it is inserted to maintain the necessary earth connection. Four pins are provided on the plug-and-socket assembly, three power cores and one pilot control core. The pilot pin is shorter than the power pins, so that on insertion it makes contact after, and on withdrawal it breaks before, the power pins, preventing their making or breaking on load.

Pliable wire armoured cables are used to power permanent and semi-permanent apparatus such as transformers and gate-end box assemblies which move up automatically as the coal-face advances. Such cables must conform to the NCB Specification 504, and range in size from 10 to 150 mm² at voltages of between 660 V and 6.6 kV. *Figure 48.24* illustrates a typical 6.6 kV pliable wire armoured cable (type 631) which has four cores insulated with EPR. A copper/nylon screen is provided over the insulation on the power cores, and all four cores are laid up around a PCP centre, over which is provided a PCP sheath. Over the inner PCP sheath is a galvanised steel strand armouring and an overall sheath of PCP.

Two, three-, four- and five-core pliable wire armoured cables of similar construction but with much smaller conductor size, e.g. 4 mm², are used for control circuits and coal-face lighting installation. Such cables are termed types 62, 64, 70 and 71, respectively.

Five-core 6 mm² flexible cables are used to power hand-held drilling machines which operate at 125 V, three-phase, 50 Hz. Type 43 has three power cores, one pilot core EPR insulated and one earth core conducting rubber covered laid around a conducting rubber cradle separator, screened with conducting rubber and a heavy-duty overall sheath of PCP. Type 44 has five EPR-insulated cores with the three power cores copper/nylon screened, laid up round a PCP centre with a heavy-duty PCP sheath overall.

Cables for telephone communication are designed to NCB Specification 492, and can be either PVC-SWA-PVC

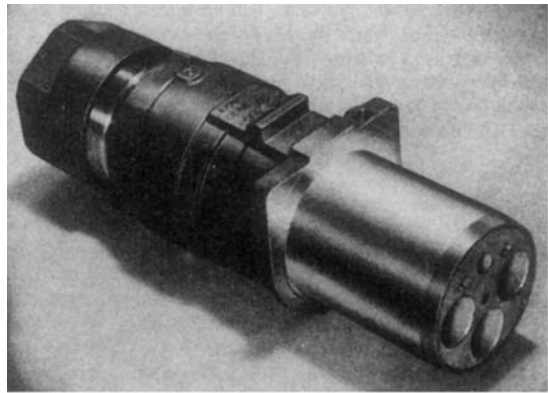

Figure 48.23 Flameproof restrained plug and socket

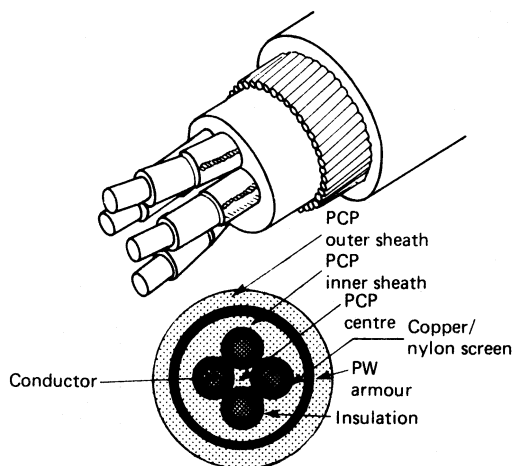
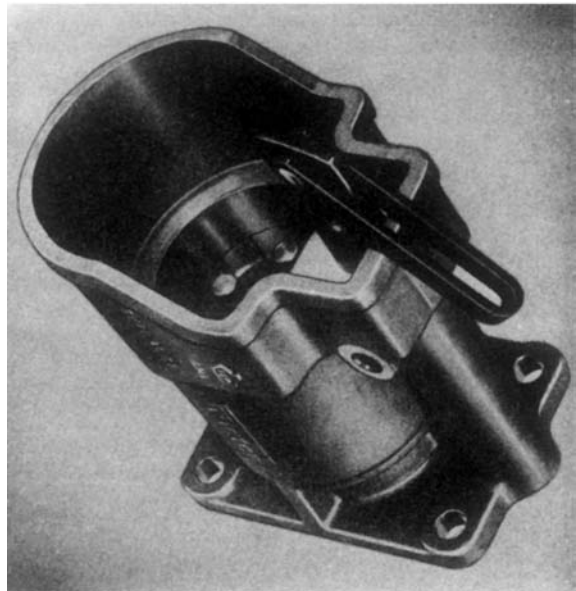

Figure 48.24 Flexible wire armoured cables

or PVC-DWA-PVC. The cores are laid up in one to 91 pairs of 1.5 mm² conductors and follow a set colour code.

Signal cables conform to NCB Specification 493, and can also be PVC-SWA-PVC or PVC-DWA-PVC. These cables have conductor sizes of 1.5 mm², ranging from 2 to 91 cores, and are laid up as single cores to a colour code.

48.12 Drilling machines

Mechanisation and automation have reduced the application of hand-held drilling machines. A typical machine is shown in *Figure 48.25*. Such machines are rated at 1.1 kW, 125 V, three-phase, 50 Hz, and operate from a purpose-designed flameproof drill panel. Drill panels are approximately the same size and shape as gate-end boxes and are designed so that they can be connected together mechanically. The drill panel contains its own step-down transformer to feed the drilling machine, contactors, protection, etc. The supply to the drill is taken from the drill panel via a 30 A flameproof plug and socket, and a five-core drill cable, consisting of three power cores, a pilot core and an earth core.

48.13 Underground lighting

Illumination underground is provided in accordance with the Coal Mines Safety and Health Regulations and to improve environmental conditions. The areas illuminated are pit bottoms, haulage stations, locomotive stations, main trunk conveyors, assembly areas and main roadways where men pass to and from their place of work.

Lighting underground is provided in four ways:

- (1) by a portable lamp carried by each person underground;
- (2) by permanent lighting installations supplied by a power transformer at 120 or 240 V, 50 Hz;
- (3) by mains lighting which forms part of a mobile machine; or
- (4) by portable compressed-air turbines.

The cap lamp (*Figure 48.26*) comprises a headpiece provided with a main 4 V, 0.9 or 1.0 A lamp and a 4 V, 0.46 A

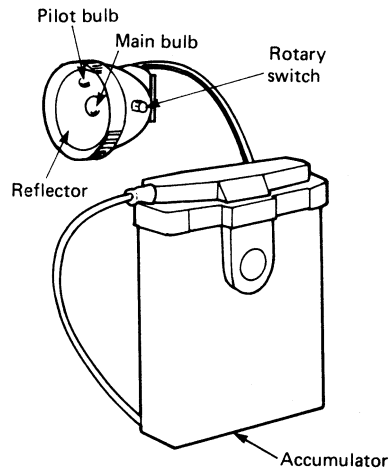

Figure 48.26 Cap lamp

pilot lamp. The headpiece, which can be carried or worn on a special helmet, is connected by flexible cable two-core 1.0 mm² vulcanised-rubber-insulated PCP sheath. The battery consists of two lead-acid cells in a polycarbonate moulded case giving 4 V output. A fuse is provided in the battery top to afford protection. The capacity of the batteries is 13 or 16 A-h.

The assembly was covered by BS 4945, but this has been superseded by the European Norm CENELEC 50 033: 1986, i.e. BS 6881:1987.

To prevent interference underground, all lamps are locked and sealed before issue at the surface lamp room. *Figure 48.27* shows a typical lamp-room layout. The miner enters the lamp room and collects his own personal cap lamp before entering the mine. On his return he places his lamp on the charging rack in the lamp room, when recharging commences automatically. During the period between shifts, the lamps are examined, cleaned and topped up ready for the next period of duty.

Permanent lighting installations below ground are similar to those provided on the colliery surface, viz. filament, fluorescent, discharge, sodium, and mercury lamps, in substantial

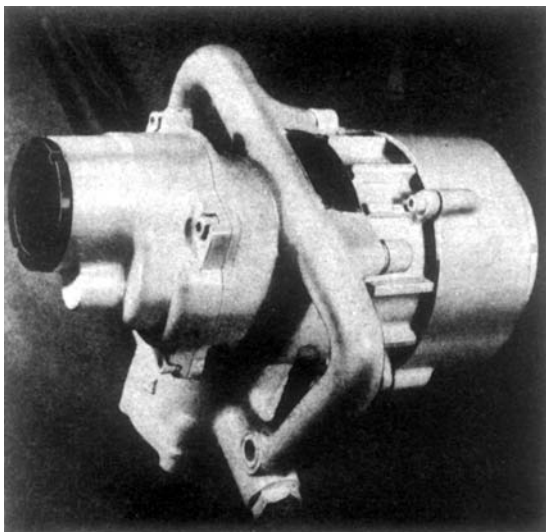

Figure 48.25 Hand-held drilling machine

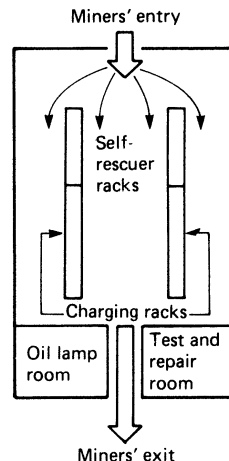

Figure 48.27 Layout of a lamp room

dust-proof fittings outside hazardous areas, and flameproof to group I (methane) in the hazardous areas. Special attention is paid to the design of electric circuits, proper loading, and fault protection, i.e. earth fault, overload and short circuit.

Illumination on mobile machines is provided by equipment designed and tested for the automotive industry but fitted into flameproof lights with protection to prevent damage. In mining development work where the heading is progressively moving, the provision of lighting on machines is advantageous.

Coal-face lighting has had a long history. Numerous approaches and types have been used but have failed for various reasons. The conditions imposed by the Coal Mines Act 1911 limited such installations to 'naked-light mines' only; it was not until 1934 that mains lighting on the face in safety lamp mines was permitted. In 1973 mains fed intrinsically safe lighting was developed using 12 in., 8 W fluorescent tubes on a high-frequency supply. This has resulted in a smaller, lighter, more easily maintained system.

48.14 Monitoring and control

Different types of monitoring and control systems are in use at collieries: either 'surface only' installations, designed as for other industries, or 'surface/underground' systems, which are specifically designed for use underground, requiring IS.

A typical system for use underground consists of a surface control or central station, a number of two-way transmission links (called 'rings') to convey data over distances up to 8 km, to and from numbers of underground FLP/IS out-stations to which are connected sensors for monitoring and control facilities. These systems may perform individual functions (e.g. coal clearance by remotely controlling conveyors, environmental monitoring, pumping, or fan monitoring), or may be multifunctional.

A surface control or central station would consist of a mini-/micro-computer, controlling a number of transmission rings. Transmission rings are usually from two- to six-wire time division multiplex data transmission systems, capable of approximately 500 bit/s, coupled to a maximum of 32 outstations. Some frequency-multiplex systems are used: in this case the signals are passed along armoured low-loss coaxial cable. Audio frequencies, modulated low radio frequencies or modulated v.h.f. frequencies are employed.

The out-stations, sited underground near to the plant concerned, are constructed part FLP to give a number of IS supplies from 110/240/550 V, and part non-FLP to house the printed circuits and terminations. The out-stations are required to collect information from various sensors and other circuits, pass this information to the transmission rings and receive from them surface information and commands. Action can then be taken by the out-station on these commands, or independently appropriate shutdown and alarm action can be taken through fault-tripping logic, according to the state of the protective sensors and other monitors associated with the plant.

Where possible, all circuits are designed for 'failure to safety'; therefore a.c. signals are preferred, with the final control operator being a relay, supplied through an isolating transformer or 'diode pump' circuit, fed through two high-voltage series capacitors, the relay being energised in the healthy state.

On/off sensor signals are obtained using a half-wave rectifier at the sensor end and an a.c. IS supply to provide open- and short-circuit cable protection.

The surface control (*Figure 48.28*) could be in an air-conditioned room and may house many separate control and monitoring systems, together with a data collection computer system, using larger disc storage. The electrical supply is taken from a source as near to the colliery feed as possible, through constant voltage transformers (CVTs) to give as clean and permanent a supply as possible.



Figure 48.28 A surface control room

48.14.1 Computer system

48.14.1.1 Hardware

A list of the hardware used is given below.

- (1) Mini- and/or micro-computers;
- (2) floppy or hard disc loading and data storage;
- (3) all parity checks utilised; 'watchdog'-type timer system; system scan time with 1 s;
- (4) two-colour graphic visual display units (VDUs) displaying mimic representation of system (faults, alarms etc.) in different areas of the screen;
- (5) keyboard used to effect system changes and issue commands;
- (6) print—300 baud rate of print-out shift analysis of data, breakdown, etc.;
- (7) suitable intrinsically safe interface to the underground transmission system;
- (8) all changeable-type ROMs, marked to a standard by the suppliers; and
- (9) computer interconnections via 20 mA serial loops, terminals, VDUs, etc., connected via either 20 mA loop or VT24.

48.14.1.2 Software

Software is normally written in assembler of Coral-66 languages. Most systems have executive type control software to give safer systems and provide rapid response to real-time requirements. Software is written to be as inherently safe as possible and is resident in the memory at all times. Some systems perform periodic check sums on ROM and RAM memory, as well as transmitted data. Entry to make system changes or give commands is restricted by level of password. Some diagnostic software is available to check much of the hardware, including on-line checks of transmission data. A software system is supplied to a colliery in package form, the package containing an operating system and a set of modules or application programs from which a particular system may be configured. Configuring, carried out in password, is on a questionnaire basis and allows the operator or engineer to: add or delete items of plant control facilities (sensor, etc.); change set points, levels and limits of analogue signals; set out-station types; build, using graphics, a representative mimic of the colliery system; select data to be periodically printed; etc.

48.14.2 Underground sensors

Listed below are some of the many different types of underground sensor, together with a few of the varied monitoring applications of each.

- (1) *Temperature*: bearings, brakes, and temperature rise.
- (2) *Pressure*: barometric, fluid, and differential (for flow).
- (3) *Flow*: liquids, ventilating air, and gas.
- (4) *Proximity*: position and movement (for velocity and acceleration).
- (5) *Weight, volume, force*: belt load, static weighers, chain force, torque, and tension.
- (6) *Vibration*: bearings.
- (7) *Gas and atmosphere analysis*: methane, oxygen, carbon monoxide, carbon dioxide, humidity, dust, and smoke.
- (8) *Electrical analysis*: power, voltage, and current.
- (9) *Level*: coal/stone bunkers, and fluid level (e.g. of lubricating oil).

Most sensors, including any electronic circuitry, are designed to be IS 'fail-safe'. With on/off switching, a.c. IS voltages are used, with a half-wave rectifier at the sensor. Analogue signals are 0.4–2.0 V, or 4–20 mA. Underground sensors must be manufactured from approved materials, such as brass, to eliminate incendive sparking risks.

Analogue temperature In these measurements, by virtue of the low energy capacity of the IS supply low impedance devices such as, for example, 100 Ω platinum resistors or thermistors are used in order to enable a number of points to be monitored.

Measuring electronics are designed to be 'fail-safe' throughout and provide a variable shutdown/warning level or in some cases (such as monitoring of compressors) fixed maximum shutdown levels, for example the maximum air temperature would be 160°C and maximum oil temperature 80°C.

Pressure Measurement ranges vary from 0–0.25 kPa to measure the differential pressures across mine stoppings to 1500 bar for hydraulic pressure.

In general the lower pressures are measured using a diaphragm-type transducer, higher pressures are usually monitored by strain-gauge bridges.